



# AEG CENTRAL VACUUM SYSTEM

Owner's manual  
Type K

 **AEG**  
perfekt in form und funktion



Important Safeguards .....	9
General Information .....	10
Installation .....	10
System Test.....	11
How to use.....	11
LED Indications .....	11
LCD Screen.....	11
Bag Adaptor.....	12
Utility Valve .....	12
Overheating Protection .....	12
Overload Protection.....	12
Diagnostics And Maintenance .....	12
Filter Maintenance .....	13
Paper Bag Filter.....	13
Trouble Shooting .....	13
Images .....	14



## IMPORTANT SAFEGUARDS

When using an electronic appliance, basic precautions should always be followed, including the following:

### READ ALL INSTRUCTIONS BEFORE USING THIS VACUUM CLEANER SYSTEM.

This central vacuum power unit is intended for the removal of normal household dust.

## WARNING

To reduce the risk of fire, electric shock or injury:

- Do not use outdoors or on wet surfaces.
- Do not block the motor hood or ventilation openings and duct on the top of the power unit. Lack of ventilation airflow will cause the motor to overheat.
- Do not locate the power unit in a high temperature area or where it is inaccessible, for example, an attic or crawl space.
- Mount the power unit no less than 30cm from the ceiling or any adjacent wall and at least 70cm from the floor. Additionally, review any local codes and regulations that may apply.
- Do not allow to be used as a toy. Close attention is necessary when used by or near children.
- This appliance is not intended for use by persons (including children) with reduced physical, sensory, or mental capabilities, or lack of experience and knowledge, unless they have been given supervision or instruction concerning use of the appliance by a person responsible for their safety.
- Use only as described in this manual. Use only manufacturer's recommended attachments.
- Do not use with damaged cord or plug. If vacuum cleaner is not working as it should, has been dropped, damaged, left outdoors or dropped in water, return it to a local authorized dealer/distributor.
- Connect to a properly grounded outlet only (refer to grounding instructions).
- Do not use extension cords or outlets with inadequate current carrying capacity.
- Turn off all controls before unplugging.
- Do not unplug by pulling on cord. To unplug, grasp the plug, not the cord.
- Do not handle plug or cord with wet hands.
- Do not put any object into openings. Do not use with any openings blocked; keep free of dust, lint, hair and anything that may reduce airflow.
- This vacuum cleaner creates suction. Keep hair, loose clothing, fingers and all parts of body away from openings and moving parts.
- Do not pick up anything that is burning or smoking, such as cigarettes, matches, or hot ashes.
- Use extra care when cleaning on stairs.
- Do not pick up flammable or combustible liquids such as gasoline, or use in areas where they may be present.
- Keep your work area well lighted.
- Unplug electrical appliances before vacuuming them.
- If the supplied power cord is damaged, it must be replaced by a special cord available from the authorized local dealer/distributor.
- Do not use without dust bag and/or filter in place.

**SAVE THESE INSTRUCTIONS**

## GENERAL INFORMATION

The central vacuum is designed for dry pick-up of household dirt and dust. Avoid picking up hard or sharp objects with this system to prevent hose and plastic pipe damage or clogs.

This manual will cover the final steps of installation of the power unit in your home. It will also provide the necessary information for maintenance and trouble shooting, in the unlikely event that it will be needed. If you require further information about installation or inquires on the product please contact your local authorized dealer/distributor.

## INSTALLATION SAFETY EQUIPMENT

For wall preparations and cover preparations, safety equipment such as helmet, gloves, goggles and hearing protection are recommended.



## CAUTION



Use caution when drilling holes in walls as gas pipelines and water pipes and electrical wires may be present.

If you have any questions regarding the product, spare parts, service, warranty or anything else, please contact your local authorized dealer or distributor.

## GROUNDING INSTRUCTIONS

This appliance must be grounded. If it should malfunction or brake down, grounding provides a path of least resistance for electrical current to reduce the risk of electrical shock. This appliance is equipped with a cord having an equipment-grounding conductor and grounding plug. The plug must be plugged into an appropriate outlet that is properly installed and grounded in accordance with all local codes and ordinances.

## WARNING

Improper connection of the equipment-grounding conductor can result in electrical shock. Check with a qualified electrician or service person if you are in doubt as to whether the outlet is properly grounded, or if the outlet does not fit into an outlet. Do not modify the plug provided with the appliance.

## WARNING

If the supply cord is damaged, it must be replaced by a special cord available from your local authorized dealer/distributor.

## SERVICE INFORMATION

The instructions in this booklet serve as a guide to routine maintenance. For additional information, contact your nearest authorized dealer/distributor.

## RATING PLATE

The model, type, and serial numbers are indicated on the rating plate located on the control panel or motor hood. For prompt and complete service information, always refer to these numbers when inquiring about service.

## WARNING

Non-observance of the safety directions may result in bodily harm.

## PRODUCT DIMENSIONS

Refer to page 14 - Image 1

## WASTE OF ELECTRIC AND ELECTRICAL EQUIPMENT (WEEE)



This symbol on the product or on its packaging indicates that this product may not be treated as household waste. Instead it should be handed over to applicable collection point for the recycling of electronics and electrical equipment. By ensuring this product is disposed of correctly, you will help prevent potential negative consequences for the environment and human health, which could otherwise be caused by inappropriate waste handling of this product. For more detailed information about this product, please contact your local waste disposal service or the shop where you purchased the product.

## INSTALLATION

Your home is most likely already fitted with the system of plastic pipes and inlet valves and you are ready to install the central power unit. If your home is not fitted for a central vacuum system, you can contract to have the AEG-Electrolux Central Vacuum System installed by a professional by contacting your local dealer or distributor or choose to do-it-yourself.

The central power unit should be located as far away from the general living area as possible, yet accessible so you can remove the dirt receptacle, reach the filter, and inspect the central power unit. A typical location would be in a garage, where you could vacuum your car or garage area, and where emptying the dirt receptacle and cleaning the filter would be more convenient. Other suitable locations are in the basement, laundry room, or ventilated storage room.

## CAUTION



Use caution when drilling holes in walls as gas pipelines and water pipes and electrical wires may be present. Holes in the masonry are only allowable if through it its standing stability is not impaired. Holes in wood studs should be drilled. Depending on what material your home is built with, use the appropriate anchors to hang your power unit. Power unit simply slides onto mounting bracket and clicks into place.

Refer to page 14 - Image 3

- Place the central power unit in a place that is removed from the general living area. The exhaust should be easy to connect to a ventilation pipe. This can be done regardless of the house's construction material.
- Locate the two low voltage wires near the main pipe. Remove the insulation from the low volt wire. Insert the low volt wire into the spring loaded low volt connectors. Be certain you comply with your local electrical codes and regulations.

Refer to page 14 - Image 4

- Make sure there is a dedicated electric socket for the power unit.
- Plug in your CVS with the supplied power cord.

Your AEG-Electrolux Oxygen CVS does not require the assembly of a muffler. Your CVS has the muffler installed internally. You may however desire to exhaust the air outside. In this case you will need to attach the exhaust adapter. This will convert the size of the exhaust to the diameter of the central vacuum pipe.

Refer to page 14 - Image 5

- Place the power unit in order to make the exhaust pipe as short as possible. Exhausts should be limited to no longer than 5 meters.
- Keep in mind that you may need space on the sides of your central unit to be able to access the dirt receptacle.

Refer to page 14 - Image 6

- Align the power unit intake fitting to the main trunk line projecting from the wall. **DO NOT GLUE.** Attach the exhaust pipe to the motor exhaust if exhausting outdoors. Make sure the exhaust pipe is as short as possible.

**NOTE:** Mount central power unit at least 30cm from the ceiling and any adjacent wall, at least 70cm from the floor and within 1.8 m of an electrical outlet. Review any local regulations that may apply.

Refer to page 14 - Image 2

## WARNING

Do not block the hood ventilation openings on the top of the central power unit. Lack of ventilation will cause the motor to overheat.

## WARNING

Do not locate the central power unit in a high temperature area where it is inaccessible for example, an attic or crawl space.

For the ultimate in air control you have the a true HEPA filter and may be included with your choice of power unit or can be purchased from an authorized dealer/distributor. Simply attach the true HEPA filter as shown.

Refer to page 14 - Image 7

## SYSTEM TEST

Be certain to comply with local electrical codes and regulations. Plug the unit into a regular electrical outlet. You are now ready to check the installation of the unit:

- Be sure the filter is properly installed in the power unit.
- Be sure the dirt receptacle is properly secured to the power unit.
- Plug the hose into each inlet valve to be sure the electrical contacts operate properly.
- Check each inlet valve for air leaks.
- Check each pipe connection for air leaks.

Refer to page 14 - Image 8

## HOW TO USE CENTRAL VACUUM SYSTEM

Your central vacuum system is controlled by a switch on your hose. Simply insert the hose into the valve and turn the switch to the on position. This will start the power unit and the flow of air.

When you are finished, turn the switch on the hose to the off position and remove the hose from the inlet valve. When unplugging the hose, hold the inlet cover open for a few seconds to allow suction to decrease thus, protecting the inlet valve seal.

Refer to page 14 - Image 8

## LED INDICATIONS - OPTIONAL DEPENDING ON MODEL

Your machine may be equipped with some or all of the indicators listed below.

Refer to page 14 - Image 9



On/Off



Motor Fault



Dirt Receptacle Full



Reset

Your power unit is equipped with a multi color LED panel. This LED panel will provide you with necessary information on your power unit's performance, maintenance and diagnostics. Below are descriptions of the different messages the power unit will provide.

## NORMAL OPERATION

When the power unit is OFF and considered to be in standby mode the LED button will be RED.

When the power unit is ON and in use the LED will be GREEN. When the motor fault light is ON see further description below. When the dirt receptacle light is ON, empty dirt receptacle, press the RESET button and hold for 10 seconds.

## MOTOR FAULT

In the case of a blown fuse or disconnected motor wire and the power unit is not functioning the ON/OFF button will be constantly GREEN In the case of an over current shutdown, the ON/OFF button will be flashing RED, the GREEN light will on and off rapidly and the MOTOR FAULT light will be AMBER and turn on and off rapidly. This fault will reset automatically in 15 seconds if the low volt connection is OFF at the hose.

In the case of a continued over current and the low volt connection is ON and the hose the ON/OFF button will constantly be RED, the GREEN light will flash slowly and the MOTOR FAULT will slowly flash AMBER.

In the unlikely event of a bad frequency received by the power unit the power unit will not start and the ON/OFF button will remain constantly RED. In the case of a high line voltage received by the power unit the ON/OFF button will alternate between RED and GREEN three times- pause briefly – alternate between RED and GREEN three times – long pause- and then repeat. This will continue until the line voltage returns to the correct level.

## LCD SCREEN - OPTIONAL



Refer to page 14 - Image 8

In the main screen of the LCD, the AEG-Electrolux logo will appear. This logo may scroll from side to side to avoid the image ingraining itself onto the LCD Display. You will see the logo when the power unit is not in use.

The button that best lines up with the Power symbol on the screen can be used to activate the unit. Press this button to toggle the unit on/off. The unit may also be activated from any installed inlet.

When your LCD power unit is in standby mode the four white lights on your LCD unit will light up in sequence and alternate moving from left to right then reversing right to left. This pattern will repeat continuously and is an indication that your power unit is ready for use and functioning properly.

## IN USE



When in use, the power indicator turns green. The 4 progressive performance bars will appear. A normally functioning unit should have all 4 performance bars lit. If there are consistently less than 2 bars, you should check for the problem. Possible issues causing the performance bars to lessen could be:

1. Blocked suction at the hose end
2. Clogged pipe in system
3. Air restrictive tool being used, such as a crevice tool
4. Full dirt receptacle
5. Clogged filtration system

## EMPTY DIRT RECEPTACLE



Every 25 hours of use (approximately 6 months) the empty dirt receptacle indicator will flash on the screen. This is an indication to check the dirt receptacle and empty it. Since this is time based, you may find the dirt receptacle too empty or too full. If you have pets, a workshop or other factors that cause waste more frequently, you may wish to check the dirt receptacle more frequently.

Once the dirt receptacle is emptied, you push the return button to reset the 25 hours timer. If your power supply is interrupted, or otherwise unplugged, the empty dirt receptacle indicator will keep a memory of its previous status and continue life measure.

To manually reset the Empty Dirt Receptacle indicator, simply press the button lining up with the Enter symbol and hold for 10 seconds. 

## LIFE METER



The life meter has 8 bars on it. Once these bars are depleted you unit will continue to run, although it is strongly recommended to take it to your local authorized dealer/distributor to be inspected and serviced. A life bar will deplete every 65 hours of vacuum use, meaning your central vacuum will have a long life of service to you. The life meter can be reset only by your service technician. If your power supply is interrupted, or otherwise unplugged, the life meter will keep a memory of its previous status and continue life measure.



## SERVICE INDICATOR

If there is a system fault, or malfunction with your power unit, the service indicator will flash. Upon seeing this symbol, we recommend that you turn the power unit off, unplug the power supply for 10 seconds and then plug it back in. If the service symbol is still on the screen, we recommend that you call for service.

This symbol may appear due to the following faults:

- Motor problem

- Electronic problem
- Voltage or current problem (too high or too low)
- Power unit not responding to electronics



## SCROLLING YOUR LCD

When not in use, you can scroll through the features of your LCD to observe the dirt receptacle status, life monitor measure or most recent recorded power level.



To scroll through these features simply push the button corresponding with the right pointing arrow symbol.

The next screen you will see will be the Life Meter. Scroll right further and you will find Bucket Status. Yet another scroll will show you last recorded performance levels of the power unit, using the Performance Meter on the In-Use screen. The final scroll right will show you the customer service phone number.



The button lining up with the left scroll button will allow you to scroll backwards through the screens.

## BAG ADAPTOR

Your power unit can all be fitted with a convenient paper bag for more convenient dirt disposal. For maintenance of the paper bag, please see the Paper Bag Filter section, under Filter Maintenance.

Refer to page 14 - Image 10

## UTILITY VALVE

The utility valve is similar to an Inlet valve, but is located near the power unit. This valve is present for your convenience, as it can help clean up any dirt spilled close to the central vacuum.

## OVERHEATING PROTECTION

If the circuit board reaches an elevated temperature, the power unit the power unit will not operate and the LED will be off or on LCD model the screen will be flashing. In the event of these problems, press the On/Off button, unplug hose or wait for temperature to lower. If problems persist; contact your authorized dealer or distributor.

Refer to page 14 - Image 9

## OVERLOAD PROTECTION

The central vacuum system employs features that monitor the following operating levels: AC voltage, and current draw. If the voltage is below or above standard operating voltage, high current draw or locked rotor, the power unit will not operate. In this case the On/Off button will blink until the problem ceases or on the LCD model the screen will flash. If problems persist; contact your authorized dealer or distributor. The power unit requires 30 minutes to cool down.

Refer to page 14 - Image 9

## DIAGNOSTICS AND MAINTENANCE

Reduced airflow or suction indicates the central vacuum system is not operating at maximum efficiency. If the dirt receptacle is full and the filter is clogged, no air can pass through the unit and no cleaning can take place. Instructions provided in the booklet serve as a guide to routine maintenance. Proper airflow or suction can be maintained by keeping the dirt receptacle and filter clean and the plastic tubing and hose free from clogs.

## EMPTYING THE DIRT RECEPTACLE

Most models feature dirt receptacles with windows to tell at a glance when the dirt receptacle should be emptied. In most cases, the dirt receptacle only needs to be emptied two to three (2-3) times a year. To remove the dirt receptacle, press the buttons on the receptacle handles. Remove and empty the contents. Return the receptacle by attaching the bucket to the power unit. To avoid suction loss make sure the receptacle is securely attached.

Refer to page 14 - Image 11

## FILTER MAINTENANCE

AEG-Electrolux's exclusive filter is permanent and self cleaning. However, if you have questions about your permanent self-cleaning filter, please contact your local authorized dealer/distributor.

## PAPER BAG FILTERS - OPTIONAL

The volume of the paper bag is 22 liters. A full dust bag reduces the systems performance. Depending on how often you use your central vacuum system, the dust bag may need to be changed 2-3 times per year – and can be obtained at your local dealer/distributor.

### Instructions for changing the dust bag:

1. Remove the power unit dirt receptacle
2. Loosen the dust bag from the intake tube, remove and dispose.
3. Place and press the new dust bag firmly into the tube.  
Turn the dust bag's opening to make it fasten firmly on the tube.
4. Put the dirt receptacle back on the central power unit.

## IF YOU EXPERIENCE TROUBLE WITH YOUR AEG-ELECTROLUX CENTRAL VACUUM SYSTEM, FOLLOW THE SUGGESTIONS BELOW BEFORE CALLING FOR SERVICE.

### PARTIAL/TOTAL LOSS OF SUCTION POWER

- Be sure dirt receptacle is on properly.
- Empty dirt receptacle.
- Remove debris from filter.
- Be sure each inlet valve is properly closed.

### CLEAR BLOCKAGE IN PIPES

#### Blockage in the hose

Plug hose into any inlet valve. If there is no suction through the hose after connecting at a couple of inlets, the blockage is in the hose. To clear the hose obstruction, insert a blunt instrument into the hose (garden hose, wood dowel). You can also attempt to reverse the suction through the hose to dislodge the blockage.

Refer to page 14 - Image 12 and 13

If there is one inlet valve without normal suction and you have checked for hose blockage, then the blockage is in the pipe system between the blocked inlet valve and the power unit (see instructions below).

Insert the hose into the inlet valve where there is no suction; hold your hand over the hose end. Release hand quickly. Repeat several times. If blockage does not clear, contact your nearest AEG-Electrolux dealer/distributor.

## POWER UNIT WILL NOT START

- Check for blown fuse or circuit breaker in main house electric supply box.
- Unplug and check all wall inlet and low voltage connections for loose wires.
- If unit still will not start, contact your nearest local authorized dealer/distributor.

## POWER UNIT WILL NOT STOP

- Check inside each inlet valve for obstruction of low-voltage contacts. If no visual obstruction can be detected, disconnect the cleaner from the power receptacle and contact your nearest local authorized dealer/distributor.

## CENTRAL POWER UNIT SHUTS OFF BY ITSELF

- Remove and then re-insert hose into inlet or toggle switch off-on located on hose handle. See "Overload Protection".

## WARRANTY

Warranty is handled by your local authorized dealer/distributor. Please contact your local authorized dealer/distributor for questions regarding warranty.

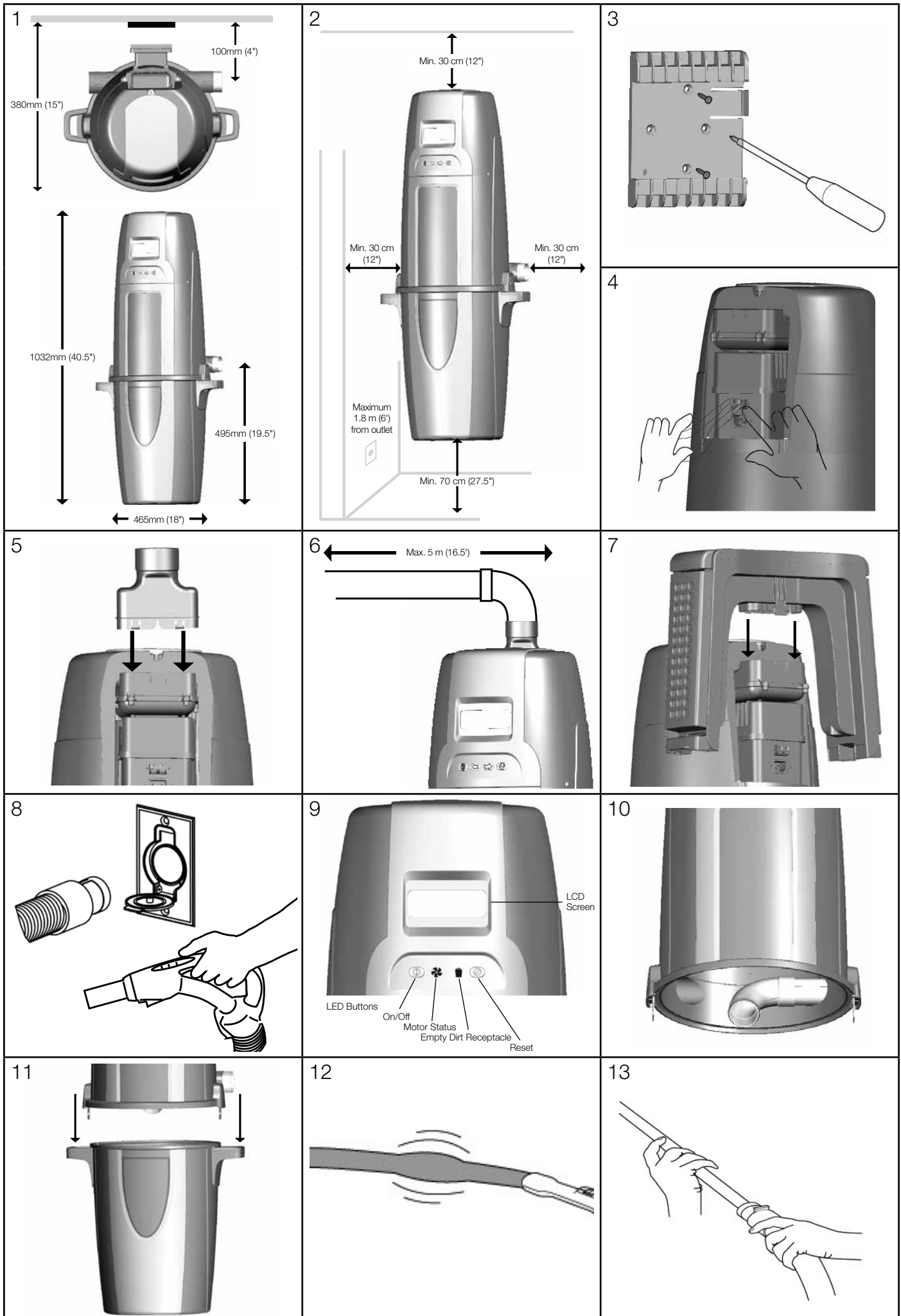

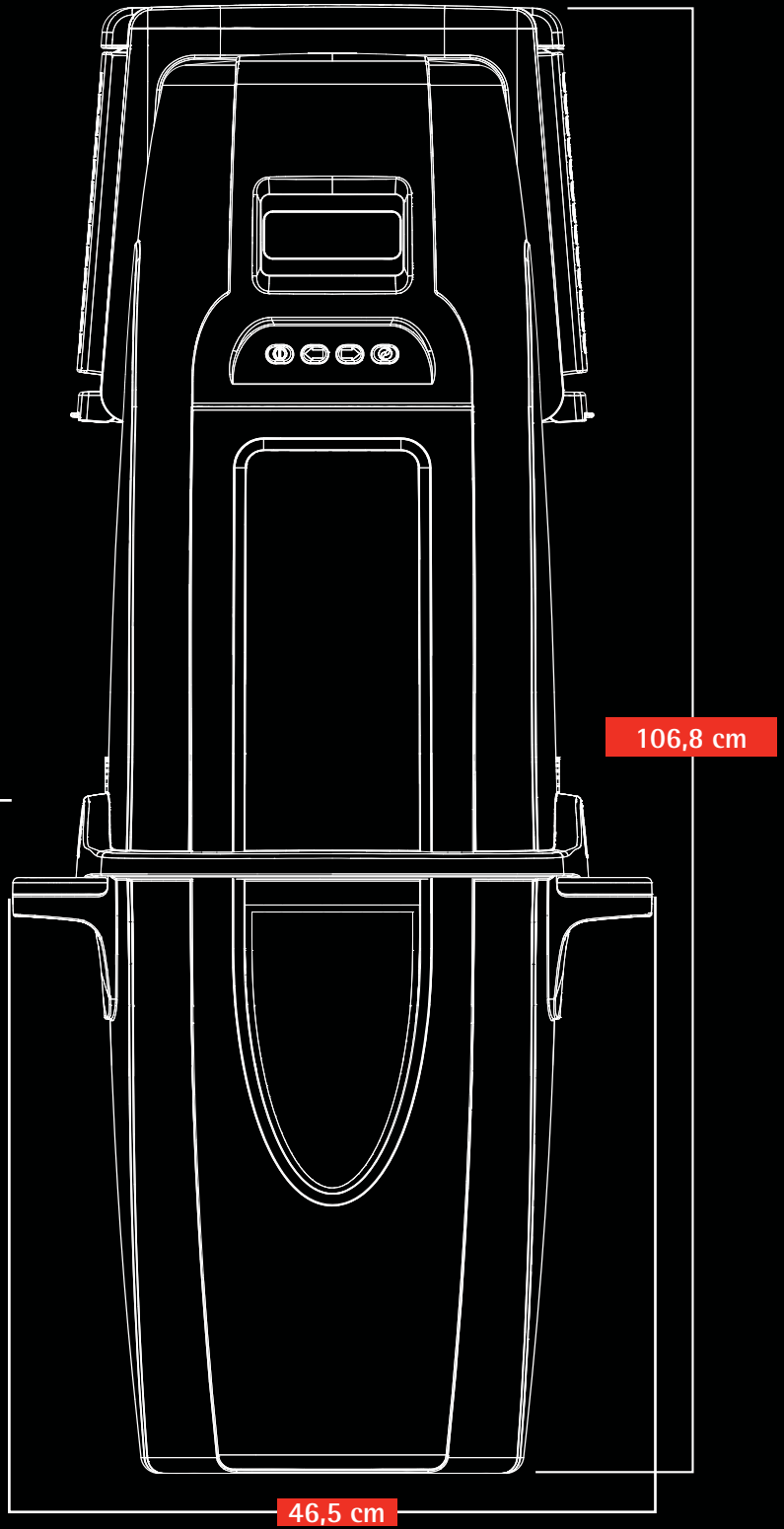
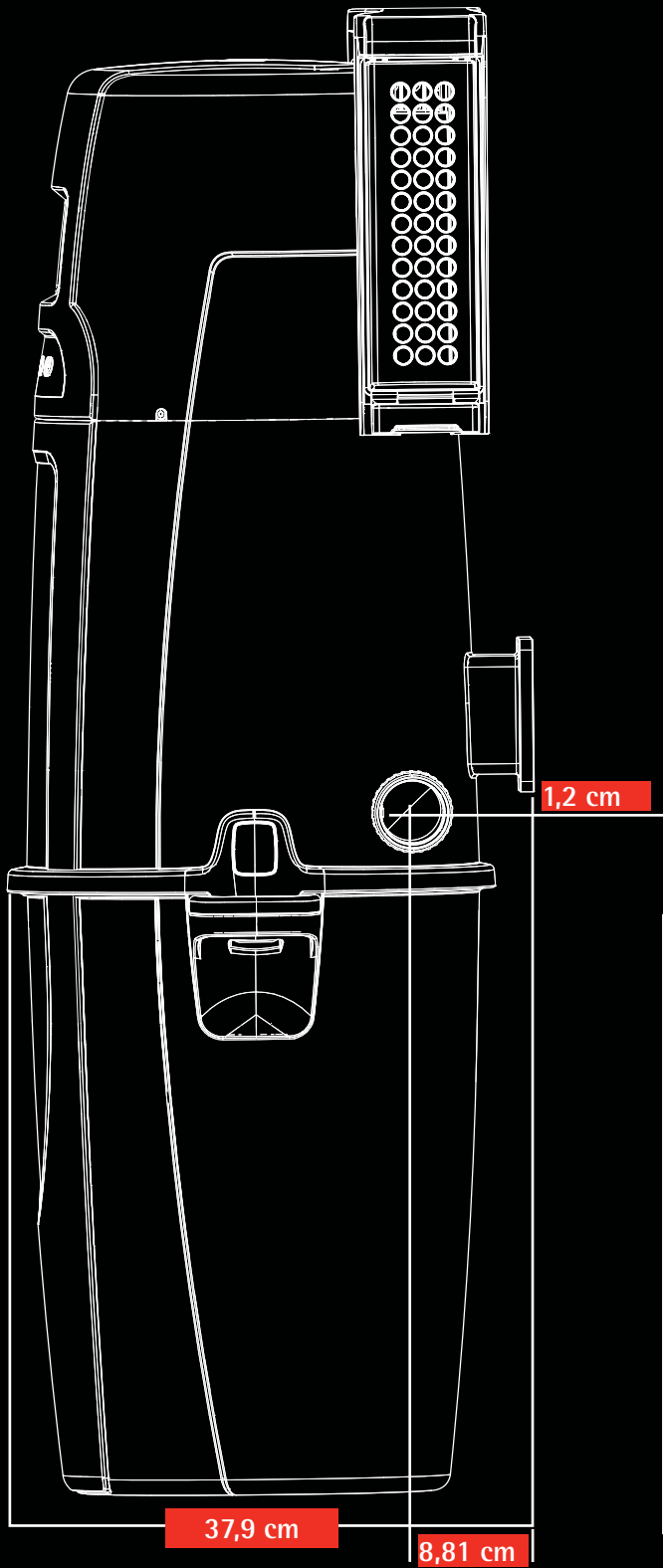



Box 60  
233 22 SVEDALA  
Sverige